

## (Electronics) Course Catalogue 2023-2024

<b>College</b>	<b>Erbil Technology College</b>	
<b>Department</b>	<b>Automation Industrial Technology Engineering (AITE)</b>	
<b>Module Name</b>	<b>Electronics</b>	
<b>Module Code</b>	<b>ELE203</b>	
<b>Semester</b>	<b>2</b>	
<b>Credit</b>	<b>6</b>	
<b>Module type</b>	<b>Core</b>	
<b>Weekly hours</b>	4	
<b>Weekly hours (Theory)</b>	( 2 )hr Class	( 118 )hr Workload
<b>Weekly hours (Practical)</b>	( 2 )hr Class	( 64 )hr Workload
<b>Lecturer (Theory)</b>	<b>Dr. Shelan M Mustafa</b>	
<b>E-Mail</b>	<b>Shelan.mustafa@epu.edu.iq</b>	
<b>Lecturer (Practical)</b>	<b>Dr. Shelan M Mustafa</b>	
<b>Email</b>	<b>Shelan.mustafa@epu.edu.iq</b>	

## Course Book

### - **Course overview:**

The prevalence of electronic gadgets in modern society has experienced a significant surge. The majority of manufacturing industries rely heavily on electronic devices to process products, communicate, operate computer systems, and power equipment. Consequently, it's crucial for every student to have a fundamental understanding of electronic component functionality, as most equipment is electronically controlled, requiring operation and maintenance. This course will cover topics such as semiconductors, diodes, rectifiers, transistors, bipolar junction transistors, and field-effect transistors.

### - **Course objective:**

The course will major in helping learners to understand the primary features of the semi-conductor electronic gadgets and components. Consequently, the learners will gain an insight on how to go about simple calculations in an electric circuit with semiconductor elements.

- **Student's obligation** ► The importance of assignments is emphasized as they will help the learner to master the various topic and subtopics involved fully. As a result, it will be necessary for every student to attempt all examinations and problems presented in the course carefully. The responses to the assignments will be provided after the submission and that no examination will be accepted after the due date. All assignments are supposed to be submitted every Monday and subsequently marked in the course of the week.

► Students are expected to be punctual in the class attendance as lateness creates disturbance to everyone. Students with an absence rate that exceeds 10% by the end of the course will not be allowed to sit for the final examination. ► Students are required to switch off their cell phones during class as they can be a source of distraction.

### - **Forms of teaching**

Learning will take place in lecture halls with data show equipment and whiteboard for class presentations. Besides, lectures, office hours, and textbooks will be essential resources for the course. Students will have two ways by which they can obtain the course resources. I will post all the lectures, LAB sheets, and assignments on my faculty website. Alternatively, you can obtain a hard copy in the subsequent classes. Theoretical lectures will be presented through data show and exemplified explained on the whiteboard within the three-hour weekly lesson. Lab sessions will run for two hours once a week.

**Assessment scheme 60%**

**Semester**

- **5%**

Homework ( Three home works are the minimum required )

- **2%**

Class Activity

- **10%**

Report, Seminar, and Project

- **10%**

Lab Report and it's activity

- **8%**

Quiz (( Three Quizzes are the minimum required)

- **25%**

10% Theory /Mid Term Exam

15% Practical /Mid Term Exam

**40% Final Exam**

**20%**Theory

**20%**Practical

**- Specific learning outcome:**

At the end of the course, the student is to be able to:

1. Explain the basic characteristics of insulators, conductors, and semiconductors.
2. Describe the atomic structure and properties of pure and doped semiconductors.
3. Describe and illustrate the operational principles of diodes.
4. Come up with a design and an analysis of a simple diode circuit.
5. Describe the various transistors and their principles of operation.
6. Demonstrate the integral parameters that are essential in defining the functioning of transistors.
7. Explain the characteristics and functionality of the bipolar junction transistors in the electronic components.
8. Describe in detail the analysis of bipolar junction transistors in direct current and develop an illustration to explain the stability behind the BJT configuration.
9. Explain the main features and functioning of field-effect transistors.
10. Work in collaboration with other students to complete laboratory exercises by following appropriate procedures.
11. Apply the relevant materials that are needed for writing lab reports.

**- Course Reading List and References:**

- Albert Malvino .Electronic Principles 8th edition,2016. McGraw-Hill Education.
- Robert L. Boylestad & Louis Nashelsky, 2011. Electronic Devices and Circuit Theory (11th Edition) , Pearson - K Lai Kishore ,2008.Electronics devices and circuits,BS Publications .
- David E. Lalond and John A. Ross , Experiments In Electronics Devices And Circuits ,1994. DELMAR publishers INC.
- Schaum's Outline Series, Theory and Problems of ELECTRONIC,2002.McGraw-Hill

<b>- Course topics (Theory)</b>	<b>Week</b>	<b>Learning Outcome</b>
Introduction to Semiconductor materials: Introduction, Atomic Structure, Semiconductors, conductors and insulators, Semiconductor material, Doping, N-Type and P-Type Semiconductors, N-Type and P-Type Semiconductors, p-n Junctions.	1	1&2

Ministry of Higher Education and Scientific  
research

Introduction to Semiconductor materials: Diodes, Diode Characteristics, Diode Operating Conditions, Actual Diode Characteristics, Resistance Levels, Diode Equivalent Circuit, Diode Capacitors, Diode Specification Sheets.	2	3
Diode Applications: Load-Line Analysis, Series Diode Configurations, Parallel Configurations, Half-Wave Rectification, PIV (PRV), Full-Wave Rectification.	3	4
Diode Applications: Diode Clippers, Parallel Clippers, Clampers, Voltage-Multiplier Circuits, Voltage Doubler, Voltage Tripler and Quadrupler, Practical Applications.	4	4
Special Purpose Diode: Zener Diode, Zener Region, Temperature Coefficient, Zener Diode (Fixed $V_i$ and R), Zener Diode (Fixed $V_i$ , Variable RL), Optical Diodes, Light-Emitting Diode (LED).	5	3&4
Bipolar junction transistor: Transistor, Transistor Construction, Transistor Operation, Currents in a Transistor, Operating Regions.	6	5
Bipolar junction transistor: Approximations, Alpha ( $\alpha$ ), Beta ( $\beta$ ), BJT CHARACTERISTICS & PARAMETERS.	7	6
Transistor bias circuits: Biasing, Operating Point, The Three States of Operation, DC Biasing Circuits, Fixed Bias, The Base - Emitter Loop, Collector-Emitter Loop, Saturation.	8	7
Transistor bias circuits: Load Line Analysis, Circuit Values Affect the QPoint, Emitter-Stabilized Bias Circuit, Base-Emitter Loop. Collector-Emitter Loop, Improved Biased Stability, Saturation Level.	9	8
Transistor bias circuits: Voltage Divider Bias, Approximate Analysis, DC Bias with Voltage Feedback, Base-Emitter Loop, Collector-Emitter Loop, Base-Emitter Bias analysis, PNP Transistors.	10	8
Field effect transistor: Introduction, JFET, JFET Biasing, JFET Characteristics and Parameters, JFET Drain Curve, JFET Transfer Characteristic, JFET Characteristics and Parameters.	11	9

Ministry of Higher Education and Scientific  
research

Field effect transistor: JFET Forward Transfer Conductance, Transconductance, JFET Input Resistance, JFET Biasing Circuit, FET Biasing- Self bias, JFET Midpoint Biasing-self bias-formula method.	12	9
<b>- Practical Topics (If there is any)</b>	<b>Week</b>	<b>Learning Outcome</b>
study about electrical symbols and laboratory equipment's.	1	10
Diode Biasing	2	3&10&11
Diode Characteristics	3	4&10&11
Half- wave rectification	4	4&10&11
Voltage limiting of DC and AC voltages behavior of a Zener diode	5	4&10&11
Zener Diodes: Voltage stabilization	6	4&10&11
Zener Diodes: Investigating the Currents	7	4&10&11
LEDs: Dynamic IR Characteristics	8	4&10&11
LEDs: Investigating the Phototransistor	9	5,6,&10&11
Transistors: Use of transistors for switching	10	7&10&11

Transistors as an Amplifier: Common emitter circuit	11	8&10&11
Transistors as an Amplifier: Common collector circuit	12	8&10&11

Ministry of Higher Education & Scientific Research  
Erbil Polytechnic University.  
Erbil Technology College  
**Automation Industrial  
Technology Engineering**



Academic year: 2023 – 2024  
Final Examination— Spring Semester  
Attempt: Final, 1<sup>st</sup>

Class: First(2<sup>nd</sup> Semester)  
Module: Electronics  
Code: **ELE203**  
Time: **120 Min**  
Date: 29 \ 05 \ 2024

**Q1/**

40 Mark

**A) In Fig.1**

- Determine the minimum input voltage required for regulation to be established, assume an ideal diode with  $I_{ZK}=1.5 \text{ mA}$  and  $V_Z=14\text{V}$ . [10M]
- Repeat problem *i* with  $Z_R=20\Omega$  and  $V_Z=14\text{V}$  at  $30 \text{ mA}$ . [10M]

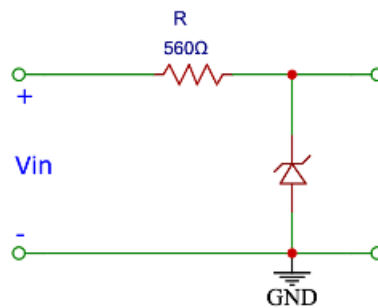

**Fig.1**

**B) From Fig.2, Assume the ideal diode, sketch the output wave form. [10M]**

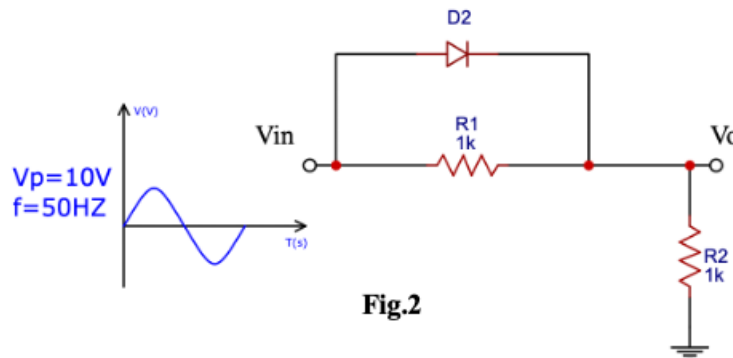

**Fig.2**

**C) For each question, answer T for true and F for false. [10M]**

- Schottky diodes have Low forward voltage drop.
- Laser diodes are primarily used in Fiber-optic communication.
- Tunnel diodes are capable of operating at frequencies up to Several kilohertz (kHz).
- When a free electron enters the p region of a junction diode, it becomes a majority carrier.
- Pentavalent impurity is added to pure silicon to get an excess of holes.

Continue

Ministry of Higher Education and Scientific  
research





30 Mark

**Q2/**

A full-wave bridge rectifier with a **35V, 50HZ** sinusoidal input has a load resistor of **5 k $\Omega$** . Assuming silicon diodes, what is:

- Peak output voltage? The average value? The dc value? [5M]
- Peak load current? The average value? The dc value? [5M]
- Peak diode current? The average value? The dc value? [5M]
- Output frequency? [5M]
- Power dissipation for each diode? [5M]
- Sketch the output waveform? [5M]

30 Mark

**Q3/**

From **Fig.3**, find  $I_B$ ,  $I_C$ ,  $V_{CE}$ ,  $V_C$  and  $V_B$ ?  $\beta=100$

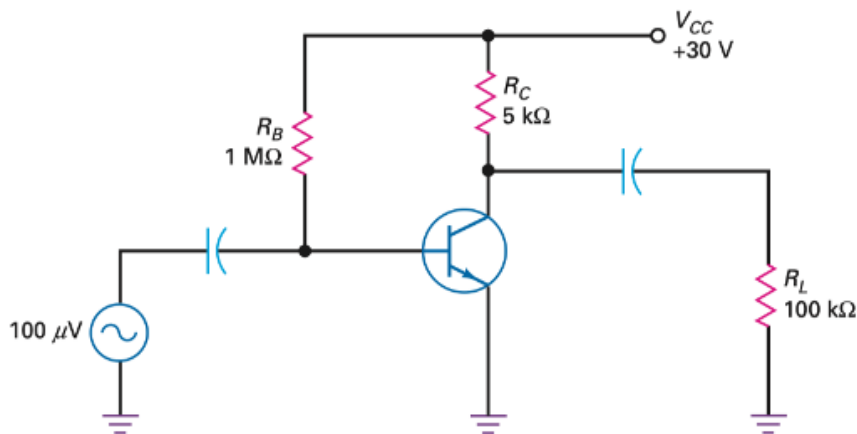

**Fig.3**

*Good Luck and best Wishes*

- **Extra notes:**

- **External Evaluator**

The course-book is well organized, and it is a suitable learning for first-stage students in the field of electrical technology.

**Muhammed A. Ibrahim**

Professor

Salahaddin University

Electronics and Communication Dep.

mabdulbaki@su.edu.krd