

Module (Course Syllabus) Catalogue

2022-2023

College/ Institute	Erbil Technical Engineering College	
Department	Civil Engineering	
Module Name	Engineering Drawing	
Module Code	END105	
Degree	Technical Diploma <input type="checkbox"/>	Bachler <input checked="" type="checkbox"/>
	High Diploma <input type="checkbox"/>	Master <input type="checkbox"/> PhD <input type="checkbox"/>
Semester	1 st	
Qualification	B.Sc.	
Scientific Title	Engineer	
ECTS (Credits)	8	
Module type	Prerequisite <input type="checkbox"/>	Core <input checked="" type="checkbox"/> Assist. <input type="checkbox"/>
Weekly hours	6 hr	
Weekly hours (Theory)	(0) hr Class	(0) Total hrs Workload
Weekly hours (Practical)	(6) hr Class	(216) Total hrs Workload
Number of Weeks	15	
Lecturer	Nazik Khalid Hasan	
E-Mail & Mobile NO.	Nazik.hasan@epu.edu.iq	
Lecturer	Mohamed Moafak Aziz	
E-Mail & Mobile NO.	Mohamed.arbili@epu.edu.iq	
Websites		

Course Book

<p>Course Description</p>	<p>Every first-year engineering student will face enough troublesome subjects and Engineering Drawing is one of the toughest. It is very obvious to have a sound knowledge of drawing for an engineering student of any branch. The technical drawing subject does not only teach students about how to draw lines and points, but it is a perfect source of communication between engineers and construction sheet to make innovative designs for a better future.</p> <p>Engineering Drawings are those drawings that found very helpful for many industries to make their productive layout on a sheet of paper to get higher productivity. Students should know the drawing fundamentals, abbreviations and symbols. An engineering drawing is a legal document (that is, a legal instrument), because it communicates all the needed information about "what is wanted" to the people who will expend resources turning the idea into a reality. Engineering drawing is a basic course for all undergraduate Engineering programs. Though Engineering drawing is considered as the language of engineers, most of the universities offer this course, as a practical course without any lecture component.</p>
<p>Course objectives</p>	<p>Engineering drawing is a basic course for all undergraduate Engineering programs. Though Engineering drawing is considered as the language of engineers, most of the universities offer this course, as a practical course without any lecture component.</p> <p>This course is aimed at providing a basic understanding of the fundamentals of Engineering Drawing; mainly visualization, graphics theory, standards & conventions of drawing, the tools of drawing and the use of Drawings in engineering applications.</p> <p>The topics covered are based on the syllabus for undergraduate studies in engineering. The course is planned to include sufficient simulations which would help the student in visualization of three-dimensional objects and developing the drawing.</p>
<p>Student's obligation</p>	<ol style="list-style-type: none"> 1-Attendance. 2- Completion of all tests. 3-Exams. 4- quizzes. 5- Home works. 6- Project.
<p>Required Learning Materials</p>	<p>Lecture halls with data show equipment for lecture presentations, white board, overhead projector, posters.</p>

Evaluation	Task		Weight (Marks)	Due Week	Relevant Learning Outcome
	Paper Review				
	Assignments	Homework	20%	2-12	1, 2,3,4
		Class Activity	20%	2-12	1, 2,3,4
		Report			
		Seminar			
		Essay			
		Project			
	Quiz		4%	4,6,7,8	1, 2,3,4
	Lab.				
	Midterm Exam		16%	6-9	2,3,4
	Final Exam		40%	13-15	1, 2,3,4
Total		100%			
Specific learning outcome:	<p>1- Learn about important tools for drawing. This will give students basic knowledge of technical drawings.</p> <p>2- Learn how to draw the lines, circles, shapes and others which is essential for engineering.</p> <p>3- Understand the main idea of using scale and dimension for engineering drawing.</p> <p>4- Familiarize different drawing procedures for sketching of geometric figures. This will give students ability to draw two- and three-dimension objects on the paper.</p>				
Course References:	<ul style="list-style-type: none"> •Technical Drawing 4th edition by; Geotsch, Nelson, chalk. •Engineering Drawing and Design 6th edition by: Jensen Helesel Short. •The fundamentals of engineering drawing & Graphic technology 3rd edition 				

Course topics (Theory & Practical Topics)	Week	Learning Outcome
Drawing Tools, Types of Lines, Learn Using of Drawing Tools and recognizing types of Lines for Drawings.	1	1-2
Scale, Miniaturization & Enlargement of any object on paper.	2	2-3
Geometrical Construction principle Part 1, Bisect a line, draw perpendicular to a line at a point on the same line, draw a perpendicular to a line from a point not on the line, draw a line parallel to a straight line at a given distance, bisect an angle, draw a pentagon (5 sides).	3	2-4
Geometrical Construction principle Part 2, Draw a hexagon (6 sides), draw an octagon (8 sides), construct an arc tangent to any angle, construct an arc tangent to a straight line & a curve, construct an arc tangent to two radii or diameters (state 1), construct an arc tangent to two radii or diameters (2 circles), (state 2).	4	2-4
Geometrical Construction principle Part 3, Construct an arc tangent to two radii or diameters (2 circles), (state 3), draw an ellipse (concentric circle method).	5	2-4
Dimensioning, replacing a dimension on an Object or any shape.	6	3-4
An orthographic Projection, Draw views of an object (Front. Side & Top View).	7	4
An orthographic Projection, Draw views of an object (Front. Side & Top View).	8	4
An Isometric, Draw Pictorial View of an Object.	9	4
An Isometric, Draw Pictorial View of an Object.	10	4
Sectional view, draw projection view of an object after cutting it by imaginary cutting plane.	11	4
Sectional view, draw projection view of an object after cutting it by imaginary cutting plane.	12	4

Examinations:

Note:

All dimensions are in millimeter (mm).

- Scale 1:1
- Do not erase light construction lines.
- Put the dimensions on the views & shapes.

Q1: Construct the objects shown below using the giving dimensions. (40 Marks)

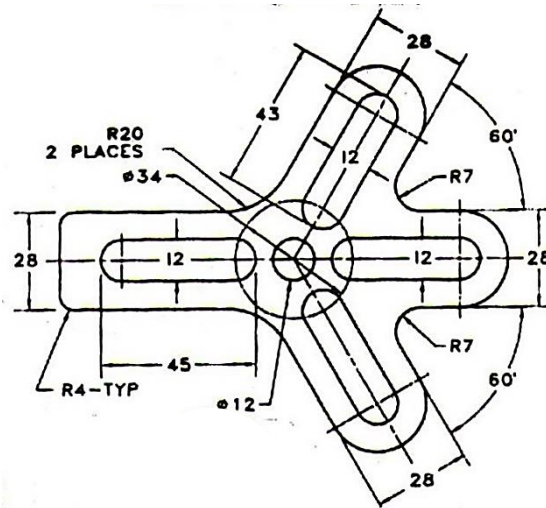

Q2: Fig. 1 Shows the pictorial view of an object. Draw: (60 Marks)

Front half removed by section A-A.

Sectional Front view in direction of (F).

Side view.

Top view.

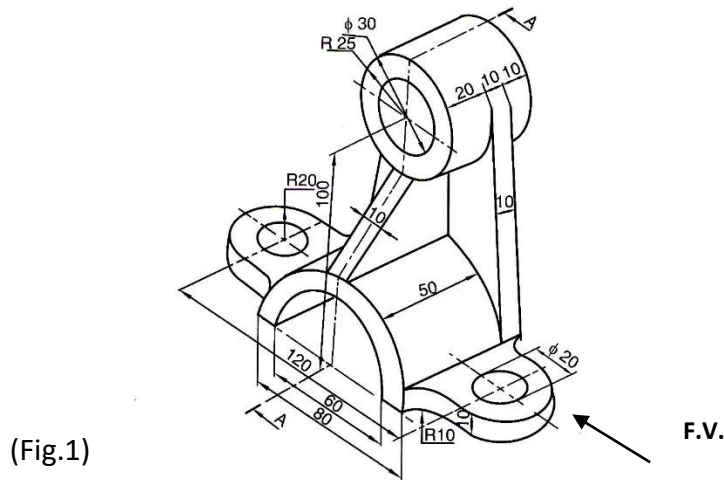

(Fig.1)

Extra notes:

External Evaluator

As a lecturer I have reviewed the Course Book related to the subject of Engineering drawing for first year, Department of Civil Engineering, College of Technology, I found that the Course Catalogue is very good describing the aim and objectives of the subject. Moreover, it is covering all the required syllabus and contents of the course and describes satisfactorily the aspects related to the course.



Dr. Bahman Omar Taha
Lecturer
Ph.D. in Structural Engineering.