

## Module (Course Syllabus) Catalogue 2023-2024

College/ Institute	Technology college	
Department	Information and Communication Technology Engineering	
Module Name	Control system	
Module Code	COS602	
Degree	Technical Diploma <input type="checkbox"/>	Bachelor <input checked="" type="checkbox"/>
	High Diploma <input type="checkbox"/>	Master <input type="checkbox"/> PhD <input type="checkbox"/>
Semester	6 <sup>th</sup> semester	
Qualification	Electrical and Electronic Engineering	
Scientific Title	Assistant Lecturer	
ECTS (Credits)	5	
Module type	Prerequisite <input type="checkbox"/>	Core <input checked="" type="checkbox"/> Assist. <input type="checkbox"/>
Weekly hours	4	
Weekly hours (Theory)	(2) hr Class	(135) Total hrs Workload
Weekly hours (Practical)	(2) hr Class	(135) Total hrs Workload
Number of Weeks	12	
Lecturer (Theory)	Jabbar Majeed Sadeq	
E-Mail & Mobile NO.	<a href="mailto:jabbar.sadeq@epu.edu.iq">jabbar.sadeq@epu.edu.iq</a>	07504487044
Lecturer (Practical)	Jabbar Majeed Sadeq	
E-Mail & Mobile NO.	<a href="mailto:jabbar.sadeq@epu.edu.iq">jabbar.sadeq@epu.edu.iq</a>	07504487044
Websites		

# Course Book

<p><b>Course Description</b></p>	<p>An introductory course in control theory: system modeling, simulation, analysis, and controller design. Description of linear, time-invariant, continuous-time systems, differential equations, transfer function representation, block diagrams, and signal flows. System dynamic properties in time and frequency domains, performance specifications. Basic properties of feedback. Stability analysis: Routh-Hurwitz criterion, Root Locus method, Bode gain, and phase margins, Nyquist criterion. Classical controller design in time and frequency domain: lead, lag, lead-lag compensation, rate feedback, PID controller. Laboratory work consists of experiments with a DSP-based, computer-controlled servomotor positioning system, and MATLAB and Simulink assignments, reinforcing analytical concepts and design procedures.</p>
<p><b>Course objectives</b></p>	<p>At the end of this course, the successful student will be able to:</p> <ol style="list-style-type: none"> <li>1. Demonstrates competency in modeling and analysis of a SISO, continuous, LTI control system in a single feedback loop configuration, including specific tasks of defining a system's analytical description, its stability, and its dynamic response. Uses relevant computer simulation software, MATLAB, and Simulink. Identifies and carries out steps required in performing system stability and dynamic response analysis.</li> <li>2. Implements a PID controller on a real-time control system (servomotor), including obtaining experimental data. Applies the control theory learned to predict the performance of the PID-controlled servomotor.</li> <li>3. Describes the differences between the theoretical (linear) model and the implemented design on a real-life system. Assesses accuracy of the results, verifying experimental data and explaining sources of possible discrepancies.</li> <li>4. Identifies and carries out steps required in designing an in-the-loop controller (PID and Lead-Lag) for a low-order LTI system to meet a set of specifications.</li> <li>5. Evaluate the chosen controller design by verifying its performance against a set of criteria, which can explain differences between expected and actual results.</li> <li>6. Demonstrates proficiency in the use of high-performance engineering modeling and analysis software, including Matlab, Control Systems Toolbox, and Simulink, for control system analysis and design, in this course and for subsequent engineering practice.</li> </ol>
<p><b>Student's obligation</b></p>	<p>The student should attend the class every week for four hours prepare himself for weekly quizzes do assignments and home works in the theory class and write a report for every experiment done weekly</p>
<p><b>Required Learning Materials</b></p>	<p>1- Powerpoint presentation 2-white board 3- sheets 3- seminars Zoom meeting and Moodle program and Matlab Program</p>

	Task	Weight (Marks)	Due Week	Relevant Learning Outcome	
	Paper Review				
	Assignments	Homework	5	3-6-9-12	Control system outcomes
		Class Activity	2	Over all weeks	Block reduction of the control system and determine the overall transfer function
		Report	5	4	Preparing a report on control system types
		Seminar	5	6	Present a seminar on control system stability and transfer function of blocks
		Essay			
		Project		6-11	
	Quiz	8	Every week	Every two weeks quiz	
	Lab.	10	Over all weeks	Every week students submit a report about their experiment that done in the lab	
	Midterm Exam	25	12		
	Final Exam	40	15	All the outcomes	
	Total	100			
<b>Specific learning outcome:</b>	<p>COURSE OUTCOMES: After going through this course the student gets:</p> <ul style="list-style-type: none"> <li>• A thorough knowledge of open loop and closed loop control systems, the concept of feedback in control systems.</li> <li>• Understanding of transfer function representation through block diagram algebra and signal flow graphs.</li> <li>• Time response analysis of different order systems through their characteristic equation.</li> <li>• Time domain specifications, stability analysis of control systems in s-domain through-H criteria.</li> <li>• Root locus techniques, frequency response analysis through Bode diagrams and Polar plots</li> </ul>				
<b>Course References:</b>	<p>REFERENCE BOOKS:</p> <ol style="list-style-type: none"> <li>1. Control Systems Theory and Applications - S. K. Bhattacharya, Pearson.</li> <li>2. Control Systems Engineering - S. Palani, TMH.</li> <li>3. Control Systems - N. K. Sinha, New Age International (P) Limited Publishers.</li> <li>4. Control Systems by S.Hasan Saeed, KITSON BOOKS.</li> <li>5. Solutions and Problems of Control Systems by A.K. Jairath, CBS Publishers.</li> </ol>				

<b>Course topics (Theory)</b>	<b>Week</b>	<b>Learning Outcome</b>
Goals for the course and course logistics. Review of terminology, objectives, and control system analysis/design procedures. General concepts of feedback and control - open vs. closed loop systems. transfer functions & block diagrams. Laplace Transform review	1	Understanding the fundamentals of the control system, types of control systems- open loop and closed loop control system
Control system block diagram reduction and overall transfer function of the control system	2	Simplifying control system blocks using the block reduction rules
Signal flow, Basic elements of a signal flow graph, construction of signal flow graph, conversion of the block diagram to signal flow graphs	3	Understanding how to convert the block diagram to signal flow graphs.
Time response analysis, transient response, steady state step signal, the impulse response of the first-order system, step response of the first-order system, second-order response system	4	Understanding to analyze the time response of a control system in first and second order system
Stability analysis in s-domain, absolutely stable system, Marginally stable system, ROUTH-HURWITZ stability Criterion, root locus technique, angle condition, and magnitude condition	5	Understanding and analyzing the stability of the control system and the Routh-Hurwitz stability criterion
System control in the time domain - classical three-mode controller - characteristics of P, PD, PI, and PID control. PID Controller tuning. Top-down design of a simple controller (PD, PI, lead).	6	Understanding system control in the time domain with three modes of CP, PI, PD, and PID
Midterm Test. Review of course materials after the midterm.	7	Mid-term Exam
Root locus method of system analysis, Proportional Control design from Root Locus plot - choosing gain.	8	Understanding root locus methods plot and gain
The root locus method of system analysis continued. PID Controller Design from Root Locus plot - choosing gain and time constants	9	Understanding root locus PID controller design
Stability in the frequency domain: gain and phase margins. Polar plots and Nyquist criterion. Frequency response of a closed loop system. Closed loop second order model in the frequency domain. Phase margin of a second order system.	10	Understanding stability in the frequency domain gain and phase margin
Correlation between frequency response and time domain response as a basis of frequency response design. Controller design in the frequency domain: lead controllers.	11	Understand the correlation between frequency and time domain
Review, of course, materials for the final exam, Questions, and answers regarding the final exam.	12	Final exam
<b>Practical Topics</b>	<b>Week</b>	<b>Learning Outcome</b>
Unity and Non-unity feedback control system using MATLAB	1	Students understand to design Unity and nonunity feedback control blocks
Block diagram reduction Using MATLAB	2	Students understand to reduce control systems blocks

Simulation of P, PD, PI, PID controller	3	Students understand to simulate P, PD, PI, PID controller
Simulation of poles and zeros of a transfer function	4	Students understand to simulate zero and pole transfer function
Plot the pole-zero configuration in s-plane for the given transfer function using MATLAB.	5	Students understand to simulate the zero-pole transfer function in S-plane
Determine the transfer function for a given closed loop system in block diagram representation		Students can able to determine the transfer function of closed-loop blocks
Mid-term practical examination	7	Mid-term examination
Plot the unit step response of the given transfer function and finds delay time, rise time, peak time, and peak overshoot.	8	Students can able to plot the unit step response curve and finds delay time, rise time, and peak overshoot
Determine the time response of the given system subjected to any arbitrary input. Using Matlab	9	Students can able to determine the response transfer function of any system to any arbitrary input
Plot root locus of the given transfer function, locate closed-loop poles for different values of k	10	Students can find the T.F and locate closed-loop poles for different values of K
Determine the steady-state errors of a given transfer function	11	Students can calculate the steady-state error for T.F
Final examination of practical experiments	12	Final practical Examination

## Questions Example Design

1. Obtain the response of unity feedback system whose open loop T.F is  $G(s) = \frac{4}{s(s+5)}$  and when the input is unit step.

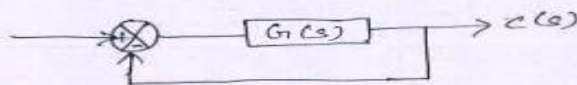

The closed loop T.F

$$\frac{C(s)}{R(s)} = \frac{G(s)}{1+G(s)}$$

$$\begin{aligned} \frac{C(s)}{R(s)} &= \frac{4/s(s+5)}{1 + \frac{4}{s(s+5)}} = \frac{4/s(s+5)}{\frac{s(s+5) + 4}{s(s+5)}} = \frac{4}{s(s+5) + 4} \\ &= \frac{4}{s^2 + 5s + 4} = \frac{4}{(s+4)(s+1)} \end{aligned}$$

The response in s-domain

$$C(s) = R(s) \frac{4}{(s+4)(s+1)}$$

Q2/ .Determine the transfer function  $Y(s)/R(s)$ .

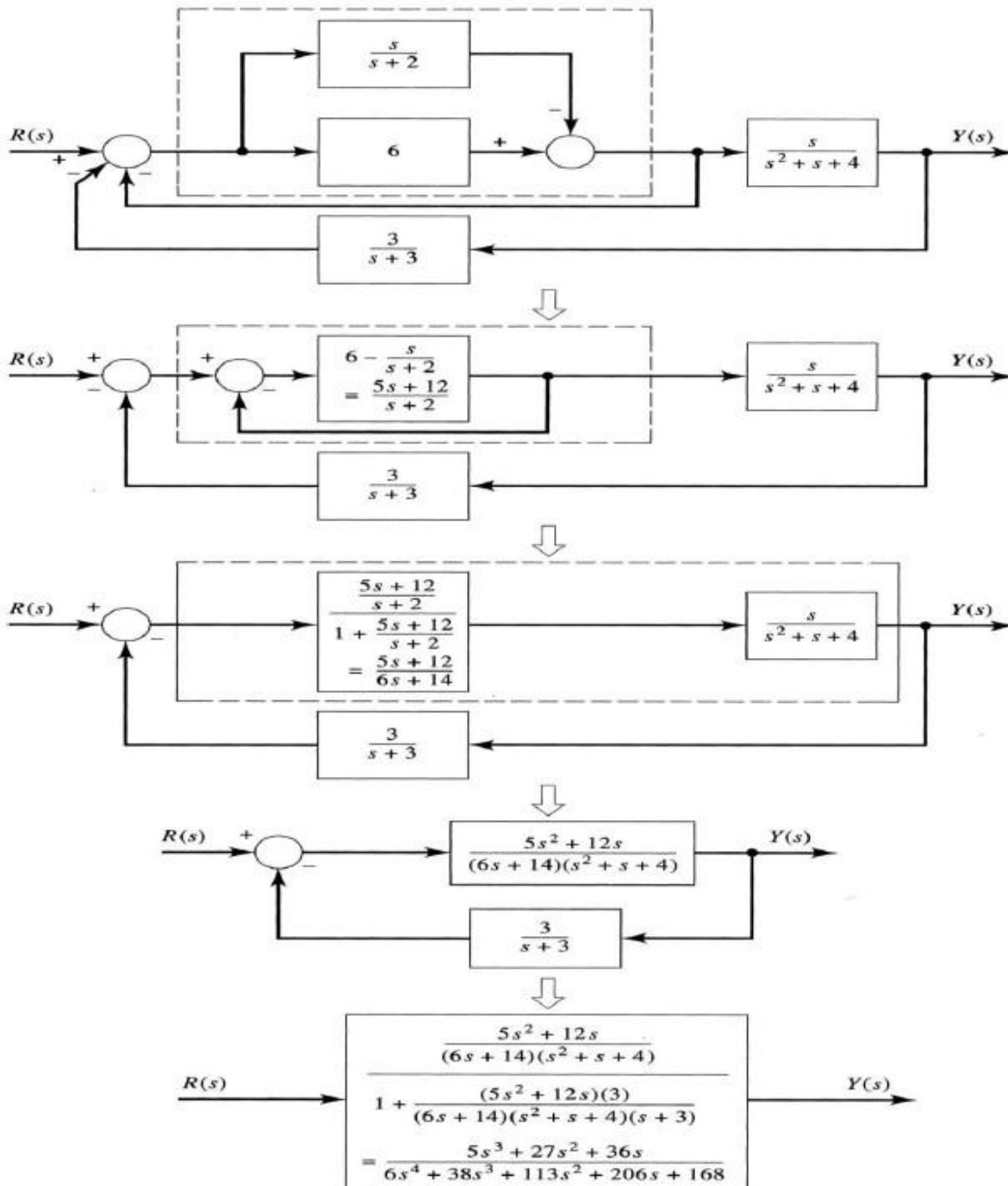

Q3/ Choose the correct answer for the following statements:

1. What is Control System?

- a) Control system is a system in which the output is controlled by varying the input
- b) Control system is a device that will not manage or regulate the behavior of other devices using control loops
- c) Control system is a feedback system that can be both positive and negative
- d) A Control System is a system in which the input is controlled by varying the output

2. Which of the following is an open-loop control system?

- a) Ward Leonard's control
- b) Metadyne
- c) Stroboscope
- d) Field-controlled D.C. motor

3. Which of the following statements is true about the Feedback control system?

- a) Equally sensitive to forward feedback path parameter changes
- b) Insensitive to both forward and feedback path parameter changes
- c) Less sensitive to feedback path parameter changes than to forward path parameter changes
- d) Less sensitive to forward path parameter changes than to feedback path parameter changes

4. In the closed-loop control system, what is the sensitivity of the gain of the overall system, M to the variation in G?

- a)  $G/1+GH$
- b)  $1/1+GH$
- c)  $G/1+G$
- d)  $1/1+G$

5. Feedback control system is basically

- a) Bandpass filter
- b) Band stop filter
- c) High pass filter
- d) Low pass filter

### Extra notes:

### External Evaluator

1- The course book on control systems is completely related to the syllabus of the control system, the practical syllabus satisfies the goal of control system subjects.

2- The practical course is completely defined by theoretical lectures.

Assit.Pro. DR. Raghad Zuhair Yosif: Lecturer at the ICTE department.