

Module (Course Syllabus) Catalogue 2024-2025

College/ Institute	Erbil Polytechnic University	
Department	Information System Engineering Techniques	
Module Name	Quantum Computing	
Module Code	QUC104	
Degree	Technical Diploma <input type="checkbox"/>	Bachler <input type="checkbox"/>
	High Diploma <input type="checkbox"/>	Master <input checked="" type="checkbox"/> PhD <input type="checkbox"/>
Semester	1 st	
Qualification	PhD	
Scientific Title	Asst. Prof.	
ECTS (Credits)	6	
Module type	Prerequisite <input type="checkbox"/>	Core <input checked="" type="checkbox"/> Assist. <input type="checkbox"/>
Weekly hours		
Weekly hours (Theory)	(3) hr Class	(30) Total hrs Workload
Weekly hours (Tutorial)	(0) hr Class	(0) Total hrs Workload
Number of Weeks	14	
Lecturer (Theory)	Ismael Abdulrahman	
E-Mail & Mobile NO.	ismael.abdulrahman@epu.edu.iq	
Lecturer (Practical)		
E-Mail & Mobile NO.		
Websites	https://academicstaff.epu.edu.iq/faculty/ismael.abdulrahman	

Course Book

Course Description	<p>This course offers a comprehensive introduction to quantum computing. Students will explore the fundamental principles of quantum mechanics, quantum circuits, and algorithms. The curriculum covers a wide array of topics, from the basics of qubits and quantum gates to complex quantum algorithms and practical applications like quantum cryptography and error correction.</p>
Course objectives	<p>The primary objective of the "Quantum Computing" course is to provide students with a comprehensive understanding of quantum computing principles, algorithms, and applications. By the end of the course, students will be able to:</p> <ol style="list-style-type: none">1. Understand Quantum fundamentals including qubits, quantum gates, and quantum phenomena, differentiating quantum computing from classical computing.2. Master Mathematical Foundations: Acquire a strong foundation in complex numbers, linear algebra, and related mathematical concepts crucial for understanding quantum algorithms and transformations.3. Explore Quantum Algorithms: Study a variety of quantum algorithms, such as Grover's algorithm, Shor's algorithm, and quantum error correction techniques, and understand their underlying principles and applications.4. Apply Quantum Concepts: Learn to design and analyze quantum circuits for both single-qubit and multi-qubit systems, allowing for practical implementation of quantum algorithms.5. Examine Quantum Cryptography: Explore quantum key distribution protocols and understand the security implications of quantum computing on classical encryption methods like RSA.7. Engage in Hands-On Programming: Gain practical experience in programming quantum computers using frameworks like Quirk, Qiskit or Cirq, allowing students to implement and simulate quantum algorithms.9. Prepare for Future Applications: Prepare students to apply quantum computation techniques to various fields, including cryptography,

	optimization, and machine learning, and anticipate future advancements in quantum technology.				
Student's obligation	<ul style="list-style-type: none"> • Attendance • Quizzes / homework / simulation / seminars/reports/ projects • Exams (mid-term, final) • Homework assignments will be a mix of paperwork and electronic copies. Written homework should be finished individually, discussions with peers or instructor are allowed. You will be given one week to finish the written homework. Some of the machine problems are designed for teamwork and due day may vary. Any late submission will not be considered. 				
Required Learning Materials	<p>Note:</p> <p>Please be aware that assessment criteria may undergo alterations, including temporary adjustments to point distribution.</p>				
Evaluation		Task	Weight (Marks)	Due Week	Relevant Learning Outcome
		Paper Review			
	Assignments	Homework			
		Class Activity (attendance)	5		
		Report	5		
		Seminar	10		
		Essay			
		Project			
	Quiz	10			
	Lab.	0			
	Midterm Exam	20			
	Final Exam	50			
	Total	100			
Specific learning outcome:	<p>Upon successful completion of the "Quantum Computing" course, students will be able to:</p> <ul style="list-style-type: none"> • Demonstrate Understanding: Explain the fundamental differences 				

between classical and quantum computing, articulating the unique properties of qubits and quantum gates.

- Apply Mathematical Foundations: Solve problems involving complex numbers and apply linear algebra concepts, including vectors, matrices, eigenvalues, and eigenvectors, in the context of quantum computing.
- Design Quantum Circuits: Create and analyze quantum circuits for single-qubit and multi-qubit systems, incorporating various quantum gates and techniques, and comprehend circuit depth and complexity.
- Implement Quantum Algorithms: Implement and simulate key quantum algorithms, including Grover's algorithm, Shor's algorithm, and quantum error correction codes, using programming frameworks like Quirk, Qiskit or Cirq.
- Examine Quantum Phenomena: Analyze quantum phenomena, such as light polarization, the double-slit experiment, and entanglement, and connect these phenomena to the principles of quantum mechanics.
- Apply Quantum Cryptography: Design and assess secure communication protocols using quantum key distribution techniques, including the BB84 protocol, and analyze the vulnerabilities of classical encryption methods in the face of quantum attacks.
- Solve Real-World Problems: Apply quantum algorithms to solve practical problems in areas such as optimization, cryptography, and machine learning, demonstrating the ability to translate theoretical knowledge into practical solutions.
- Collaborate Effectively: Work collaboratively in groups to design, implement, and present quantum computing projects, demonstrating teamwork, communication, and problem-solving

	<p>skills.</p> <ul style="list-style-type: none"> • 10. Program Quantum Computers: Write code for quantum computers, understand the significance of physical vs. logical qubits, and address challenges related to decoherence and error correction in quantum computing systems.
<p>Course References:</p>	<ol style="list-style-type: none"> 1. Michael A. Nielsen & Isaac L. Chuang, “Quantum Computation and Quantum Information”, 10th anniversary edition, Cambridge University Press, 2010 2. Robert S. Sutor, “Dancing with Qubits: How quantum computing works and how it can change the world”, Packt Publishing, 1st edition, 2019 3. Jack D. Hidary, “Quantum Computing: An Applied Approach”, 2nd edition, Springer, 2021 4. Thomas G. Wong, “Introduction to Classical and Quantum Computing”, 2022 5. Ramona Wolf, “Quantum Key Distribution An Introduction With Exercises”, Lecture Notes in Physics, Springer, 2021 <p>About the author of the book “Dancing with Qubits”: Robert S. Sutor has been a technical leader and executive in the IT industry for over 30 years. More than two decades of that have been spent in IBM Research in New York. During his time there, he worked on or led efforts in symbolic mathematical computation, optimization, AI, blockchain, and quantum computing. He is the co-author of several research papers and the book Axiom: The Scientific Computation System with the late Richard D. Jenks. He also was an executive on the software side of the business in areas including emerging industry standards, software on Linux, mobile, and open source. He’s a theoretical mathematician by training, has a Ph.D. from Princeton University, and an undergraduate degree from Harvard College.</p>

He started coding when he was 15 and has used most of the programming languages that have come along.

Course topics (Theory)	Week	Learning Outcome
<ul style="list-style-type: none"> • Week 1-2: Introduction to Quantum Mechanics and Mathematical Foundations <ul style="list-style-type: none"> ▪ Comparison of classical vs. quantum computing ▪ Introduction to complex numbers and Euler's formula ▪ Fundamental linear algebra concepts: vectors, matrices, eigenvalues, and eigenvectors ▪ Unitary matrices and their role in quantum transformations ▪ Quantum phenomena: light polarization, the double-slit experiment, the three-filter polarization experiment, and the Born rule • Week 3-5: Analysis and Design of Single Qubit Systems <ul style="list-style-type: none"> ▪ Understanding qubits: properties and manipulation ▪ Dirac notation (bra-ket and ket-bra) ▪ Global phase and visualization using the Bloch sphere ▪ Quantum gates: X-gate, Y-gate, Z-gate, ▪ Quantum Hadamard gate, R_z^ϕ gate, S gate, S^\dagger gate, T gate, T^\dagger gate, \sqrt{X} gate ▪ Quantum circuits and their depth analysis • Week 6-7: Multi-Qubit Systems and Entanglement <ul style="list-style-type: none"> ▪ Tensor product and the concept of entanglement ▪ Bell states and generalized entanglement ▪ Multi-qubit gates: SWAP, CNOT, CY, CZ, general CU ▪ Three-qubit gates: Toffoli CCNOT, CSWAP Fredkin ▪ Designing quantum circuits for multi-qubit systems • Week 8-10: Quantum Algorithms <ul style="list-style-type: none"> ▪ Quantum search algorithms: Grover's algorithm and its circuit 		

- Deutsch-Jozsa algorithm and its circuit
 - Quantum Fourier Transform (QFT) and its circuit
 - Inverse QFT and its circuit
 - Phase estimation and its circuit
 - Factoring problem and its circuit
 - Order and period finding and their circuits
 - Shor's algorithm
 - Quantum error correction techniques and their circuits: correcting bit flips, correcting sign flips
- Week 11-12: Quantum Cryptography and Applications
 - Enhancing network security with quantum computing: RSA encryption
 - Quantum key distribution protocols: BB84 protocol
 - Simulation exercises: constructing circuits for Schrödinger's cat experiment
 - Differentiating between physical and logical qubits and understanding the concept of decoherence
- Week 13-14:
 - Quantum machine learning
 - Quantum optimization

Note:

This syllabus serves as a flexible guide and may be adjusted based on the class's pace and students' depth of understanding. Practical demonstrations, guest lectures, and real-world applications will be incorporated to enhance the learning experience.

Practical Topics	Week	Learning Outcome
Simulations in the form homework assignments.		

19. Examinations (samples of questions)

Q: For the circuit shown below:

1. What is the name of this algorithm?
2. What does each block do?
3. Analyze the circuit (write the matrices/vectors for the steps at each gate)
4. What is the circuit depth and circuit width?

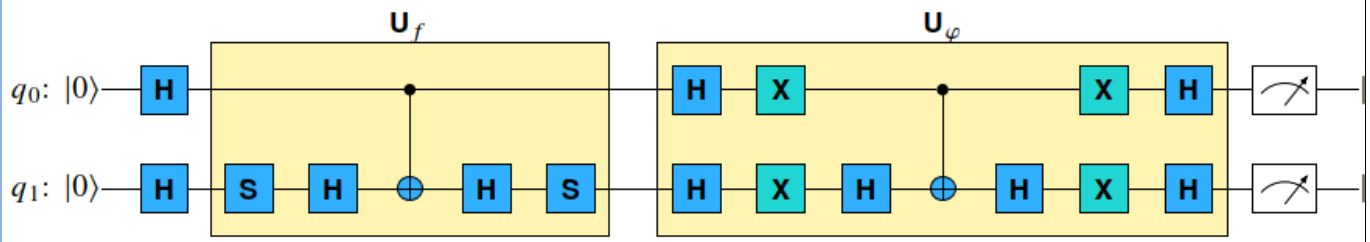

Q: The quantum circuit shown below is used for an important topic in quantum computing. What is it?

Explain it.

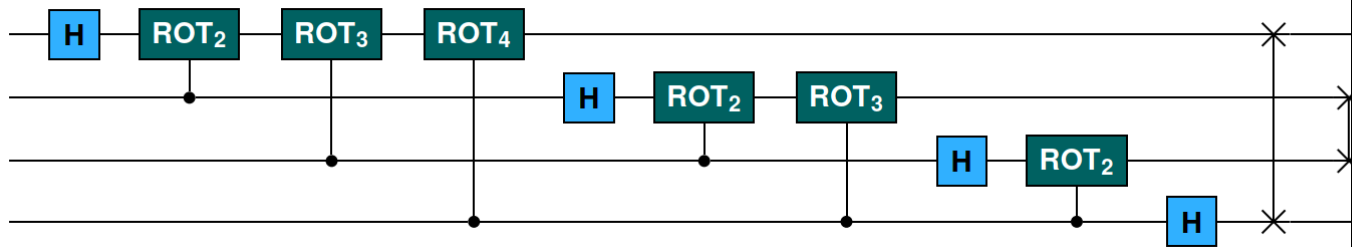

Q: Analyze the quantum circuit shown below providing the details for all steps.

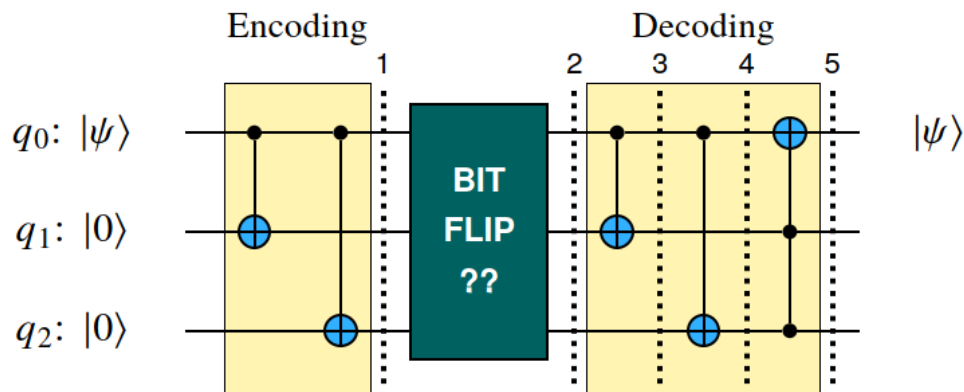

Q: Redraw the Bloch sphere shown below dropping all the related information on it.

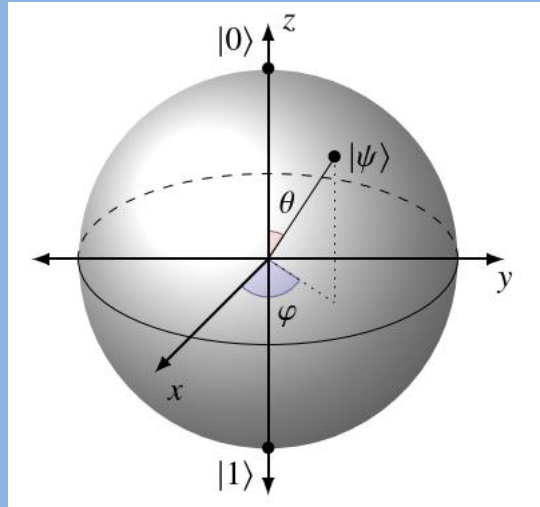

External supporting Link:

YouTube lectures are prepared and recorded by the instructor:

<https://www.youtube.com/@ismaelabdulrahman7295/videos>

External Evaluator

I confirm that the syllabus given the attached course book is sufficient and covers the required areas needed for the students.