

Module (Course Syllabus) Catalogue 2024-2025

College/ Institute	Erbil Polytechnic University	
Department	Information System Engineering Techniques	
Module Name	Principles of Electronic Circuits	
Module Code	PEC305	
Degree	Technical Diploma <input type="checkbox"/> Bachelor <input checked="" type="checkbox"/> High Diploma <input type="checkbox"/> Master <input type="checkbox"/> PhD <input type="checkbox"/>	
Semester	3 rd	
Qualification	PhD	
Scientific Title	Asst. Prof.	
ECTS (Credits)	4	
Module type	Prerequisite <input type="checkbox"/> Core <input checked="" type="checkbox"/> Assist. <input type="checkbox"/>	
Weekly hours		
Weekly hours (Theory)	(2) hr Class	(93) Total hrs Workload
Weekly hours (Practical)	(2) hr Class	(69) Total hrs Workload
Number of Weeks	14	
Lecturer (Theory)	Ismael Abdulrahman	
E-Mail & Mobile NO.	ismael.abdulrahman@epu.edu.iq	
Lecturer (Practical)	Mohamed Nabi	
E-Mail & Mobile NO.	mohammad.ahmmed@epu.edu.iq	
Websites		

Course Book

Course Description	<p>In this course, basic concepts of electricity are studied, such as charge, current, voltage, power in addition to some terms such as conductor, insulators and semiconductors besides active elements and passive elements. Many theorems are used to analysis the DC circuits, all of which will be tested practically in the lab. This course begins with a review of general terms of electricity and an introduction to analytical DC methods. You will learn terms relevant to the process of measuring the basic quantities of electricity which are Voltage, current, and resistor. In this course we can apply Ohm's Law to any simple electrical circuit continues with a KVL, KCL, superposition, Thevenin, Norton and maximum power transfer function theorems in complicated circuits. These methods allow the analysis of DC Circuits of interest. You will also learn about electronic devices which are diodes and transistors in the second part of this course. The course concludes with the electronic applications. Please keep in mind that many electricity courses, especially analysis of electricity, require laboratory experiments to reinforce these concepts; however, this course provides supplemental material in order to convey this information. After successful completion of this course, you will understand the techniques used in analysis of electrical and electronic circuits.</p>
Course objectives	<p>The course covers the basic concepts and background of electronic circuits. In the end of the course, the students be familiar with the basic concepts and laws of the electric measurements, circuit analysis, treatment with electronic devices, and good information about most common applications of electronic that they have relation with information system.</p>
Student's obligation	<ul style="list-style-type: none">• attend the university for the full academic year;• attend classes punctually and regularly;• you must all be ready to learn and ask questions. To get a lot from this course, you must invest time in the readings and assignments – this is where the depth and synthesis will happen.• collaboration on the weekly questions and on assignments is encouraged, but I expect each person to turn in their own work. I strongly advise you to consult each other once you have already attempted to figure something out; i.e., do not lean too

	heavily on others to get you through the assignments, or you will find yourself having a tough time on the exams.				
Required Learning Materials					
Evaluation	Task	Weight (Marks)	Due Week	Relevant Learning Outcome	
	Paper Review				
	Assignments	Homework	10		
		Class Activity	2		
		Report	8		
		Seminar	8		
		Essay			
		Project			
	Quiz	8			
	Lab.				
	Midterm Exam	24			
	Final Exam	40			
Total	100				
Specific learning outcome:	<p>Upon completion of this course, participants will have gained knowledge in the following:</p> <ul style="list-style-type: none"> • Theoretical backgrounds on basic laws and concepts of electronic circuit. • Theoretical backgrounds on circuit analysis techniques. • Simulation practice using Multisim program. • Practical knowledge on electronic circuits and basic concept. 				
Course References:	<ul style="list-style-type: none"> • Charles K. Alexander and Matthew n. o. Sadiku, “Fundamentals of Electric Circuits”, 5th edition, 2013. • William Hart Hayt, Jack E Kemmerly, and Steven M Durbin, “Engineering circuit analysis”, 8th edition, 2012. • J.David Irwin & R.Mark Nelms, “Basic Engineering Circuit Analysis”, 10th edition. 				

- Robert L. Boylestad , “Introductory Circuit Analysis”, 11th edition, 2007.

Course topics (Theory)	Week	Learning Outcome
<ul style="list-style-type: none"> • Basic concepts and laws including definitions, units, Ohm’s law, nodes and loops, power laws, resistors, voltage and current sources, independent sources, AC and DC, KVL and KCL laws, parallel and series configuration, voltage divider and current divider, Y to delta and delta to Y conversions, resistor colours, etc. • Nodal analysis for circuits using conventional method. • Nodal analysis for circuits by inspection using matrices. • Mesh analysis for circuits using conventional method. • Mesh analysis for circuits by inspection using matrices. • Introduction to diode and transistor • Analysis of circuits with transistors • Thevenin Theorem • Superposition Theorem • Capacitors • Inductors 		

Same topics as above.

19. Examinations (samples of questions)

Q1: By inspection, obtain the mesh-current equations for the circuit sketched below.

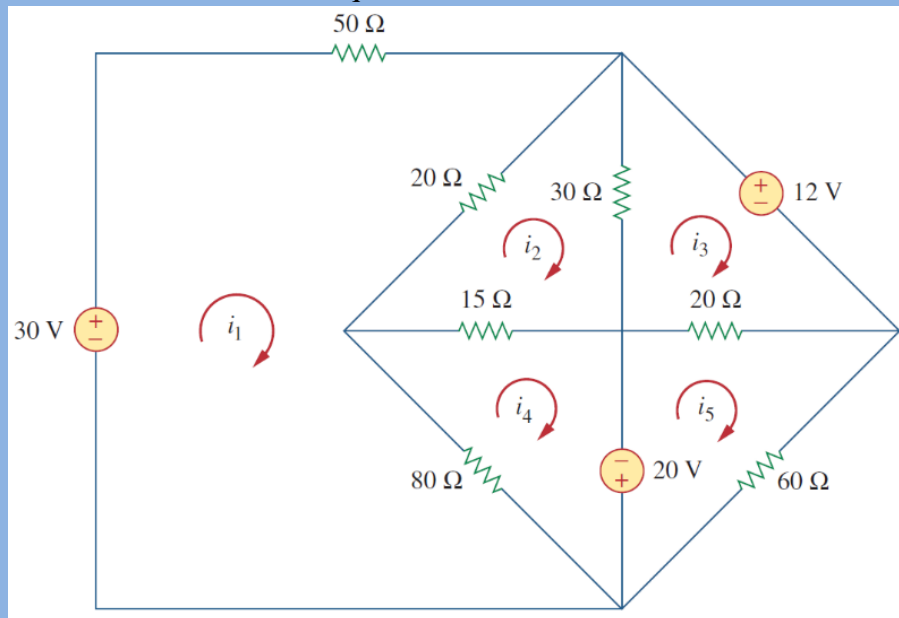

Q2: Find I_B , I_C and v_0 in the transistor circuit of the figure below. Assume that the transistor operates in the active mode and that $\beta = 50$. Redraw the circuit on your solution paper.

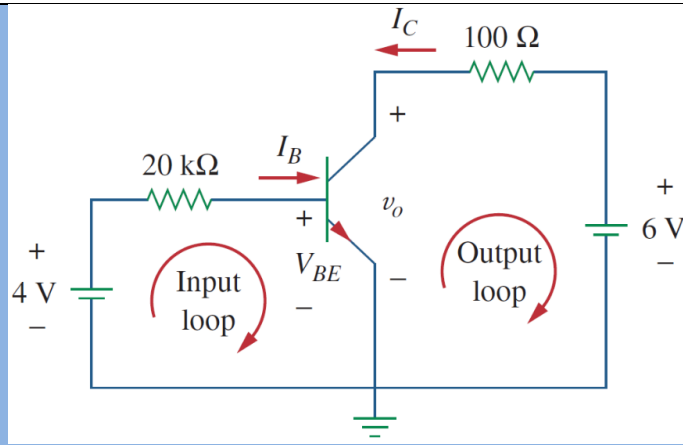

Extra notes:

Note: this course book is subject to change, add, delete, delay or push forward any subject according to the useful ways to get the students understanding the concepts of the course book.

I am available to talk with you about the class material and assignment questions. You are welcome to stop by my office, according to my schedule.

Cheating is obviously not allowed. As per the Academic Honesty statement, a first offense will cause you to get a failing grade on the assignment, and a second offense means you fail the class. If in doubt about what constitutes cheating or plagiarism, or if stress is causing you to consider this route, please come to my office to talk with me. My goal is not only to teach you the principles of electricity, but also to stir your fascination in the way the earth works! Please to not hesitate to talk to me about how I can improve your learning environment! I am committed to providing assistance to help you be successful in this course.

External Evaluator

I confirm that the syllabus given the attached course book is sufficient and covers the required areas needed for the students.

Assist. Lect. Najat Yohana Danha